



## Features

- Superior circuit protection
- Overcurrent & overvoltage protection
- Blocks surges up to rated limits
- High speed performance
- Small SMT package
- RoHS compliant\*
- Agency recognition:

## Applications

- SLIC protection
- Cable & DSL
- MDU/MTU modems
- ONT
- Voice/DSL line cards

# TBU-PL Series - TBU™ High Speed Protectors

## General Information

The TBU-PL Series of Bourns® TBU™ products are low capacitance dual bidirectional high speed protection components, constructed using MOSFET semiconductor technology, and designed to protect against faults caused by short circuits, AC power cross, induction and lightning surges.

In addition to overcurrent protection, an added feature is the voltage monitoring on the two lines. If the voltage on the line drops below  $V_{SS}$  then the voltage will trigger the device to switch to the blocking state.

The TBU™ high speed protector placed in the system circuit will monitor the current with the MOSFET detection circuit triggering to provide an effective barrier behind which sensitive electronics are not exposed to large voltages or currents during surge events. The TBU™ device is provided in a surface mount DFN package and meets industry standard requirements such as RoHS and Pb Free solder reflow profiles.

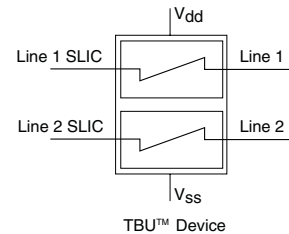

## Agency Approval

Description	
UL	File Number: Pending

## Industry Standards (in Conjunction with OVP Device)

	Industry Standard	Part Number
Telcordia GR-1089-CORE Intra-building	1500 V, 100 A 2/10 $\mu$ s 120 V RMS, 25 A, 900 s	TBU-PL050-xxx-WH
	5000 V, 500 A 2/10 $\mu$ s 120 V RMS, 25 A, 900 s	TBU-PL060-xxx-WH
ITU-T	K.20, K.21, K.45 Basic & Enhanced	TBU-PL085-xxx-WH

## Absolute Maximum Ratings (@ $T_A = 25^\circ\text{C}$ Unless Otherwise Noted)

Symbol	Parameter	Part Number	Value	Unit
$V_{imp}$	Peak impulse voltage withstand with duration less than 10 ms	TBU-PL050-xxx-WH	500	V
		TBU-PL060-xxx-WH	600	
		TBU-PL085-xxx-WH	850	
$V_{rms}$	Continuous A.C. RMS voltage	TBU-PL050-xxx-WH	300	V
		TBU-PL060-xxx-WH	350	
		TBU-PL085-xxx-WH	425	
$T_{op}$	Operating temperature range		-55 to +125	$^\circ\text{C}$
$T_{stg}$	Storage temperature range		-65 to +150	$^\circ\text{C}$
$T_{jmax}$	Maximum Junction Temperature		+125	$^\circ\text{C}$
ESD	HBM ESD Protection per IEC 61000-4-2 on line pads		$\pm 2$	kV

## Electrical Characteristics (@ $T_A = 25^\circ\text{C}$ Unless Otherwise Noted)

Symbol	Parameter	Part Number	Min.	Typ.	Max.	Unit
$I_{trigger}$	Current required for the device to go from operating state to protected state	TBU-PLxxx-100-WH	100	150	200	mA
		TBU-PLxxx-200-WH	200	300	400	
$R_{TBU}$	Series resistance of the TBU™ device		40	50	55	$\Omega$
$R_{match}$	Package resistance matching of the TBU™ device #1 - TBU™ device #2			$\pm 0.5$	$\pm 1.0$	$\Omega$
$t_{block}$	Time taken for the device to go into current limiting				1	$\mu$ s
$I_Q$	Current through the triggered TBU™ device with 50 Vdc circuit voltage		0.25	0.70	1.50	mA
$I_{SS}$	Operating current with $V_{SS} = -50$ V applied			100		$\mu$ A
$V_{reset}$	Voltage below which the triggered TBU™ device will transition to normal operating state	TBU-PLxxx-100-WH	12	15	22	V
		TBU-PLxxx-200-WH	15	20	25	
$V_{to}$	Voltage threshold offset with 60 Hz applied voltage ( $V_{SS} - V_{lineSLIC}$ )		-1.0		0.2	V
$V_{SS}$	Operating voltage range relative to $V_{dD}$		-180		-20	V
$R_{th(j-l)}$	Junction to package pads - FR4 using minimum recommended pad layout			65		$^\circ\text{C}/\text{W}$
$R_{th(j-l)}$	Junction to package pads - FR4 using heat sink on board (6 cm <sup>2</sup> ) (0.5 in. <sup>2</sup> )			40		$^\circ\text{C}/\text{W}$

\*RoHS Directive 2002/95/EC Jan 27 2003 including Annex.

Specifications are subject to change without notice.

Customers should verify actual device performance in their specific applications.

# TBU-PL Series - TBU™ High Speed Protectors

**BOURNS®**

## Functional Block Diagram

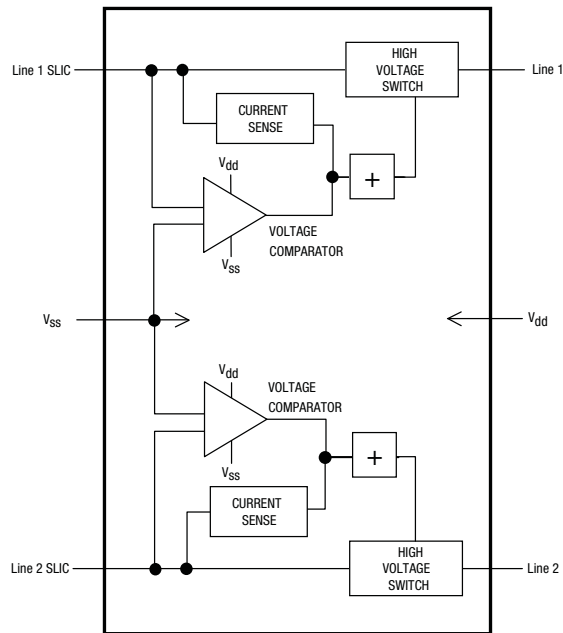

## Reference Application

The TBU-PL Series are high-speed protectors used in voice/VoIP SLIC applications. The maximum voltage rating of the TBU™ device should never be exceeded. Where necessary, an OVP device should be employed to limit the maximum voltage. A cost-effective protection solution combines Bourns® TBU™ protection devices with a pair of Bourns® MOVs. For bandwidth sensitive applications, a Bourns® GDT may be substituted for the MOV.

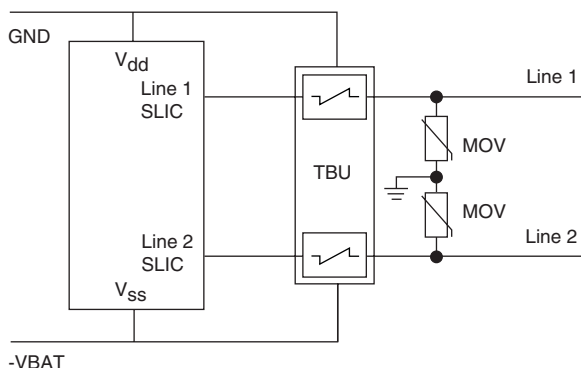

## Basic TBU Operation

The TBU™ device, constructed using MOSFET semiconductor technology, placed in the system circuit will monitor the current with the MOSFET detection circuit triggering to provide an effective barrier behind which sensitive electronics are not exposed to large voltages or currents during surge events. The TBU™ device operates in approximately 1  $\mu$ s - once line current exceeds the TBU™ device's trigger current  $I_{trigger}$ . When operated, the TBU™ device restricts line current to less than 1 mA typically. When operated, the TBU™ device will block all voltages including the surge up to rated limits.

When the voltage on the SLIC output is driven below ( $V_{bat} - V_{to}$ ) the TBU-PL series device switches to the blocking state, regardless of output current in the device.

After the surge, the TBU™ device resets when the voltage across the TBU™ device falls to the  $V_{reset}$  level. The TBU™ device will automatically reset on lines which have no DC bias or have DC bias below  $V_{reset}$  (such as unpowered signal lines).

If the line has a normal DC bias above  $V_{reset}$ , the voltage across the TBU™ device may not fall below  $V_{reset}$  after the surge. In such cases, special care needs to be taken to ensure that the TBU™ device will reset, with software monitoring as one method used to accomplish this. Bourns application engineers can provide further assistance.

# TBU-PL Series - TBU™ High Speed Protectors

**BOURNS®**

## Bourns® TBU™ Device Solution

Industry Standard	Surge & AC Tests	TBU™ Device P/N	Qty.	OVP Device P/N	Qty.
Telcordia GR-1089-CORE Intra-building	1500 V, 100 A 2/10 $\mu$ s 120V RMS, 25 A, 900 s	TBU-PL050-xxx-WH	1	MOV-07D201K	2
Telcordia GR-1089-CORE Enhanced Intra-building	5000 V, 500 A 2/10 $\mu$ s 120V RMS, 25 A, 900 s	TBU-PL060-xxx-WH	1	MOV-10D201K	2
	1500 V, 100 A 2/10 $\mu$ s 277V RMS, 25 A, 900 s	TBU-PL085-xxx-WH	1	MOV-10D431K	2
ITU-T K.20, K.21, K.45 Basic	1500 V, 40 $\Omega$ 10/700 $\mu$ s 4000 V, 40 $\Omega$ 10/700 $\mu$ s 230 V rms 10 $\Omega$ -1000 $\Omega$ , 900 s 600 V rms 600 $\Omega$ , 0.2 s	TBU-PL085-xxx-WH	1	MOV-10D391K	2
	1500 V, 40 $\Omega$ 10/700 $\mu$ s 4000 V, 40 $\Omega$ 10/700 $\mu$ s 230 V rms 10 $\Omega$ -1000 $\Omega$ , 900 s 600 V rms 600 $\Omega$ , 1 s	TBU-PL085-xxx-WH	1	TISP4400M3BJ	2
ITU-T K.20, K.21, K.45 Enhanced	1500 V, 40 $\Omega$ 10/700 $\mu$ s 6000 V, 40 $\Omega$ 10/700 $\mu$ s* 230 V rms 10 $\Omega$ -1000 $\Omega$ , 900 s 600 V rms 600 $\Omega$ , 0.2 s 600 V rms 600 $\Omega$ , 1 s* 1500 V rms, 200 $\Omega$ 2s*	TBU-PL085-xxx-WH	1	MOV-10D391K	2
	1500 V, 40 $\Omega$ 10/700 $\mu$ s 6000 V, 40 $\Omega$ 10/700 $\mu$ s 230 V rms 10 $\Omega$ -1000 $\Omega$ , 900 s 600 V rms 600 $\Omega$ , 0.2 s 600 V rms 600 $\Omega$ , 1 s 1500 V rms, 200 $\Omega$ 2s	TBU-PL085-xxx-WH	1	TISP4500H3BJ	2

\* GDT Special Test Protector with DC breakdown (DCBD) of less than 330 V.

Note: The Le9500, Le9520 and Le9530 (VE950 series) require a 200 mA  $I_{trigger}$  TBU™ device for normal operation.

## Device Pin Out

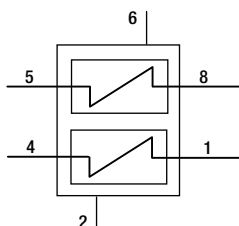

### Pad Designation

Pad #	Pin Out
1	Line 1
2	$V_{dd}$
3	Not Used
4	Line 1 SLIC
5	Line 2 SLIC
6	$V_{ss}$
7	Not Used
8	Line 2

# TBU-PL Series - TBU™ High Speed Protectors

**BOURNS®**

## Performance Graphs

### Typical V-I Characteristics (TBU-PL085-200-WH)

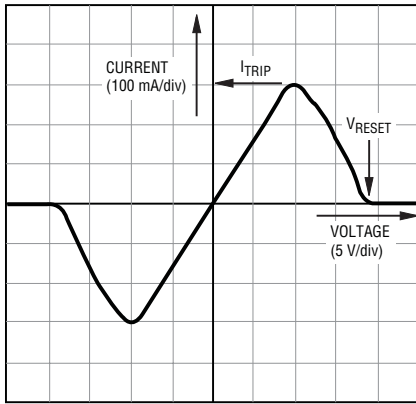

### Typical Trigger Current vs. Temperature

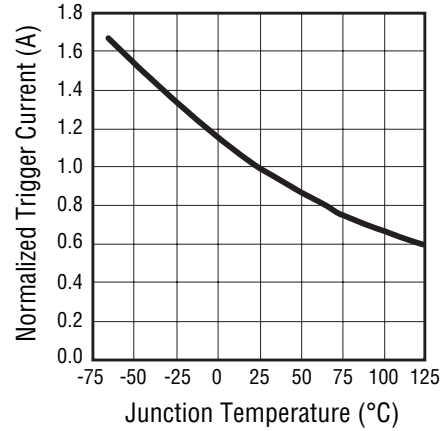

### Tracking Voltage Characteristics

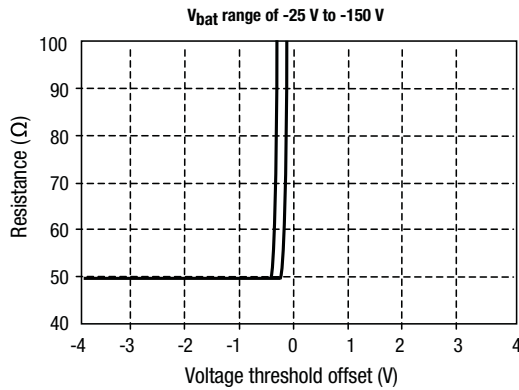

### Typical Resistance vs. Temperature

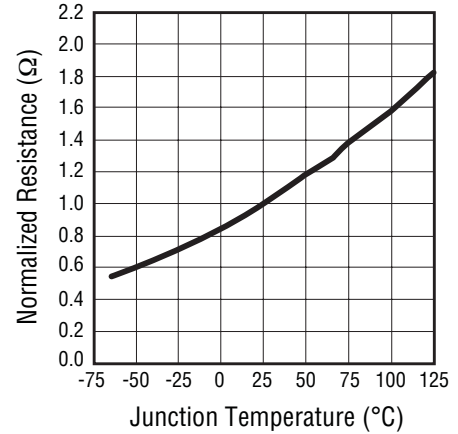

### Power Derating Curve

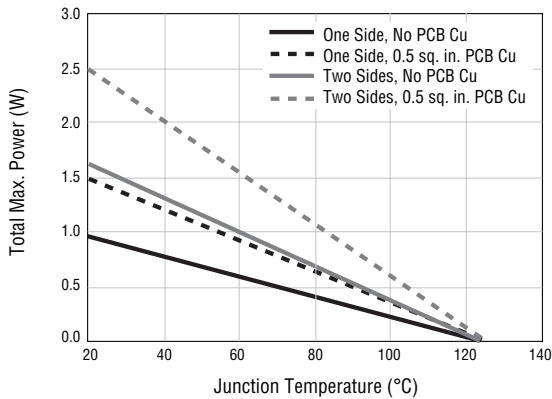

### Typical Surge Response

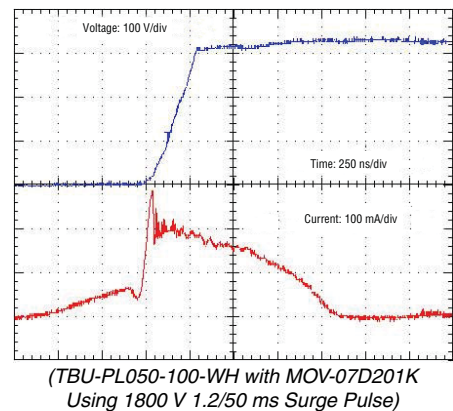

Specifications are subject to change without notice. Customers should verify actual device performance in their specific applications.



# TBU-PL Series - TBU™ High Speed Protectors

**BOURNS®**

## Reflow Profile

Profile Feature	Pb-Free Assembly
Average Ramp-Up Rate (T <sub>smax</sub> to T <sub>p</sub> )	3 °C/sec. max.
Preheat <ul style="list-style-type: none"> <li>- Temperature Min. (T<sub>smin</sub>)</li> <li>- Temperature Max. (T<sub>smax</sub>)</li> <li>- Time (t<sub>smin</sub> to t<sub>smax</sub>)</li> </ul>	150 °C 200 °C 60-180 sec.
Time maintained above: <ul style="list-style-type: none"> <li>- Temperature (T<sub>L</sub>)</li> <li>- Time (t<sub>L</sub>)</li> </ul>	217 °C 60-150 sec.
Peak/Classification Temperature (T <sub>p</sub> )	260 °C
Time within 5 °C of Actual Peak Temp. (t <sub>p</sub> )	20-40 sec.
Ramp-Down Rate	6 °C/sec. max.
Time 25 °C to Peak Temperature	8 min. max.

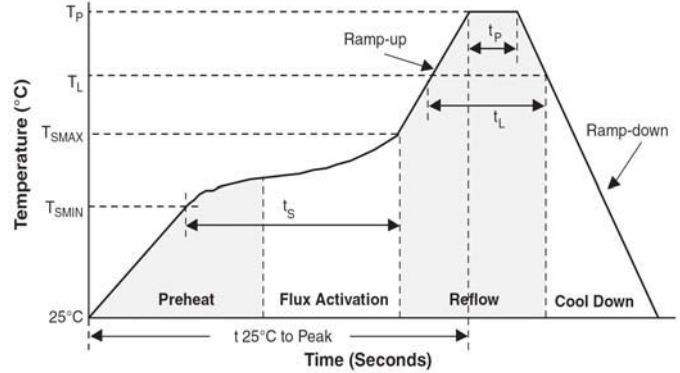

## How to Order

**TBU - PL 085 - 100 - WH**

TBU™ Product \_\_\_\_\_  
 Series \_\_\_\_\_  
 PL = Dual Bidirectional Series  
 Impulse Voltage Rating \_\_\_\_\_  
 050 = 500 V  
 060 = 600 V  
 085 = 850 V  
 Trigger Current \_\_\_\_\_  
 100 = 100 mA  
 200 = 200 mA  
 Hold to Trip Ratio Suffix \_\_\_\_\_  
 W = Hold to Trip Ratio  
 Package Suffix \_\_\_\_\_  
 H = DFN Package

## Typical Part Marking

**MANUFACTURER'S TRADEMARK**

**PRODUCT CODE**

- 1ST DIGIT INDICATES PRODUCT FAMILY: L = TBU-PL SERIES
- 2ND & 3RD DIGITS INDICATE IMPULSE VOLTAGE: 50 = 500 V 60 = 600 V 85 = 850 V
- 4TH DIGIT INDICATES TRIGGER CURRENT: 1 = 100 mA 2 = 200 mA

**PIN 1**

**MANUFACTURING DATE CODE**

- 1ST DIGIT INDICATES THE YEAR'S 6-MONTH PERIOD.
- 2ND DIGIT INDICATES THE WEEK NUMBER IN THE 6-MONTH PERIOD.
- 3RD & 4TH DIGITS INDICATE SPECIFIC LOT FOR THE WEEK.

**6-MONTH PERIOD CODES:**  
 A = JAN-JUN 2009 C = JAN-JUN 2010 E = JAN-JUN 2011  
 B = JUL-DEC 2009 D = JUL-DEC 2010 F = JUL-DEC 2011

# TBU-PL Series - TBU™ High Speed Protectors

# BOURNS®

## Packaging Specifications

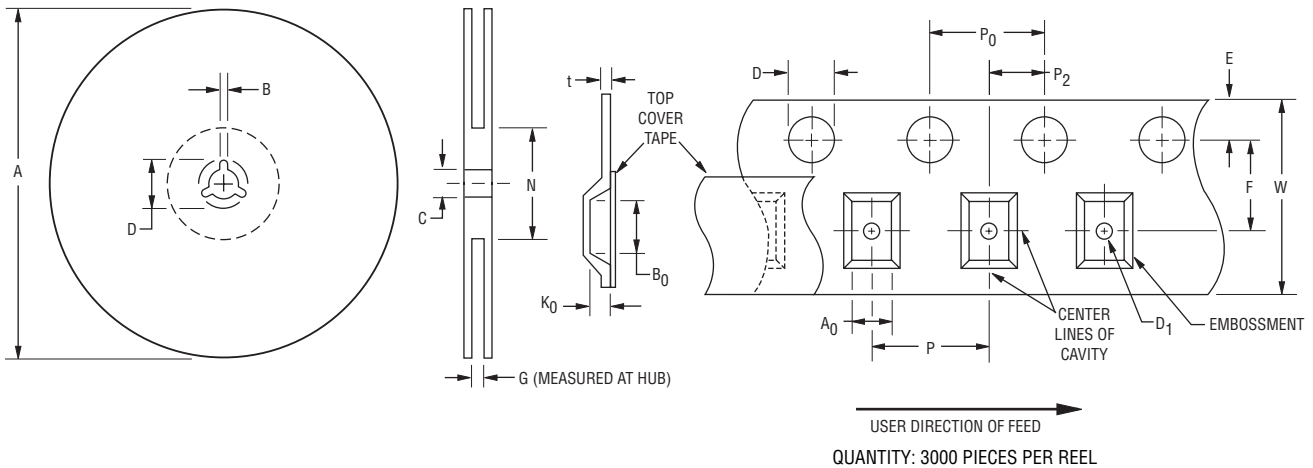

A		B		C		D		G	N
Min.	Max.	Min.	Max.	Min.	Max.	Min.	Max.	Ref.	Ref.
326	330	1.5	2.5	12.8	13.5	20.2	-	16.5	102
(12.835)	(13.002)	(.059)	(.098)	(.504)	(.531)	(.795)		(.650)	(4.016)

A0		B0		D		D1		E		F	
Min.	Max.	Min.	Max.	Min.	Max.	Min.	Max.	Min.	Max.	Min.	Max.
4.30	4.50	6.70	6.90	1.5	1.6	1.5	-	1.65	1.85	7.4	7.6
(.169)	(.177)	(.264)	(.272)	(.059)	(.063)	(.059)		(.065)	(.073)	(.291)	(.299)
K0		P		P0		P2		t		W	
Min.	Max.	Min.	Max.	Min.	Max.	Min.	Max.	Min.	Max.	Min.	Max.
1.0	1.2	7.9	8.1	3.9	4.1	1.9	2.1	0.25	0.35	15.7	16.3
(.039)	(.047)	(.311)	(.319)	(.159)	(.161)	(.075)	(.083)	(.010)	(.014)	(.618)	(.642)

DIMENSIONS:  $\frac{\text{MM}}{\text{(INCHES)}}$

## BOURNS®

**Asia-Pacific:** Tel: +886-2 2562-4117 • Fax: +886-2 2562-4116

**Europe:** Tel: +41-41 768 5555 • Fax: +41-41 768 5510

**The Americas:** Tel: +1-951 781-5500 • Fax: +1-951 781-5700

[www.bourns.com](http://www.bourns.com)